

No.: A00002-002E

Used blister packaging line CAM Italy in the years 2002 and 2003 (description of all machines in the line below the photos) consisting of: blistering machine, cartoner and wrapper, chiller. The line is currently installed and in excellent working condition. Professional desmantling, packaging and shipment is available upon request (at additional cost).

Old Price: 138.500,00 EUR ---- NEW Price: 132.500,00 EUR







**Used line for packing tablets (or capsules into blisters, blisters into cartons and wrapping.
Manufacturer: CAM.**

The line includes:

1. Blistering machine made by CAM Italy model M92X (M92.216)

Year of manufacturing: 2002

Capacity: 30-35-40-45 cycles per minute

Maximum stroke: 180 mm.

Maximum foil width: 286 mm.

Maximum filling depth: 12 mm

Overall dimensions: L 4700 x W 2020 x H 2890 mm

Hour counter: 14600 hours.

Full technical documentation available.

Videos of working machine available machine upon request.

Current installed blister formats:

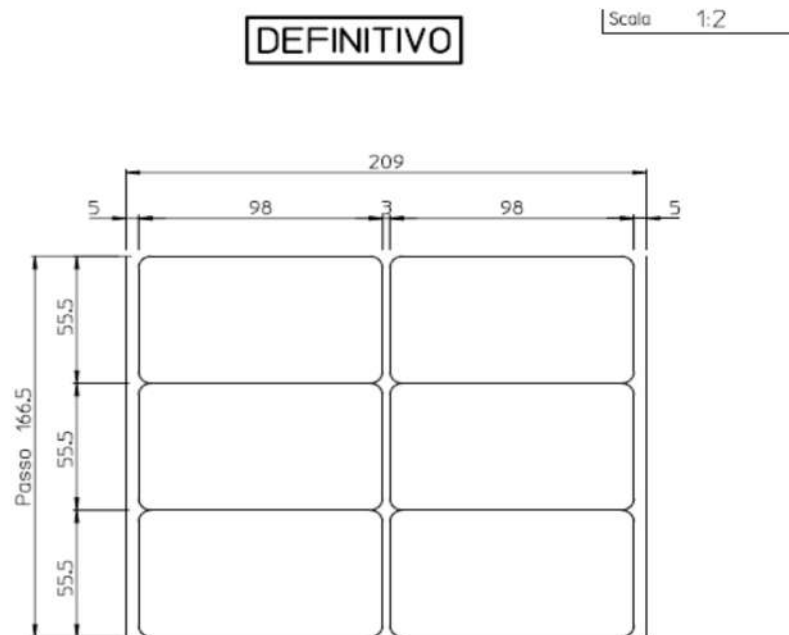

Materiale di copertura

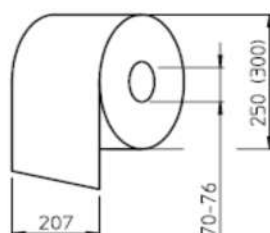

Materiale di formatura

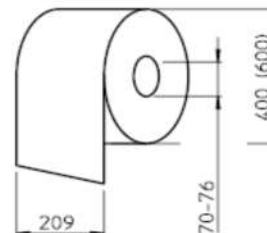

2. Cartoner by CAM Italy model HV (16189.HV_1.07) with leaflet feeder

Year of manufacturing 2002

Capacity per minute: max 400 cycles

Possibility to pack various products, machine configured for blister packaging.

Total power: 5.2 kW

Overall dimensions: length 4520 x width 1700 x height 1625 mm

Hour counter: 14600 hours.

Full technical documentation available.

Videos of working machine available upon request.

Machine capable of making described below format range:

a) format range

2.3 - ZAKRES FORMATOWY

mm	MIN.	MAX.	MAX.
A	20	95	160
B	12	70	70
C	70	230	230
		HV/1	HV/2

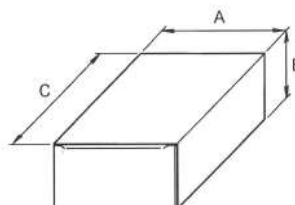

HV/1=A+B min. 32 max.165 mm
HV/2=A+B min. 32 max. 230 mm

b) leaflet feeder

Material na ulotki:

- papier gładki o gramaturze 40+60 gr/m².

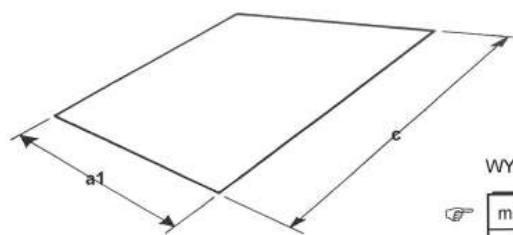

WYMIARY ULOTKI

mm	MIN.	MAX.
a1	80	297
a	18	45
c	80	210

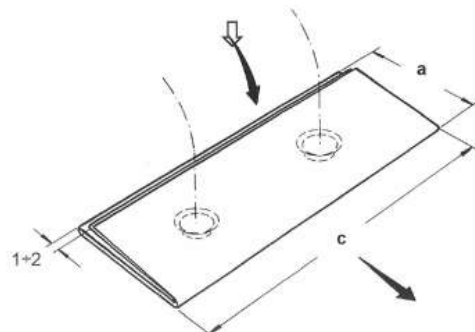

3. Wrapping machine by CAM Italy model G35

Year of manufacturing 2003.

Film width – 185mm

Number of cycles per minute: 6-35

Total input power: 3.5 kW.

Overall dimensions: dl. 2635 x W 1595 x H 1635mm

Hour counter: 14600 hours

Full technical documentation available.

Videos of working machine available upon request.

Machine format range:

Zakres formatowy

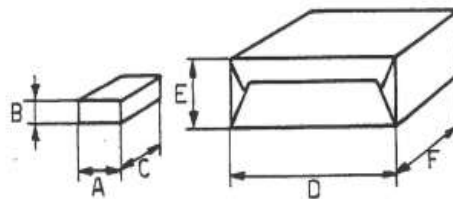
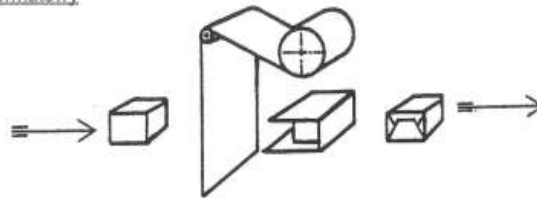

	A	B	C	D	E	F
min, mm	15	10	50	50	30	50
max mm	300	90	200	300	150	300

4. Chiller by Kelvin model KAW132

Tank volume 40 L.

Cooling capacity: 3840 W.

